

# ioLogik E2210

## Active Ethernet I/O with 12 digital inputs and 8 digital outputs



- > Instant event messaging by TCP/UDP/email/SNMP-trap
- > Easy-to-use Click&Go™ Logic for local output control
- > 12-point 24 VDC digital input with counter
- > 8-point 24 VDC digital output with pulse output
- > PC-based configuration utility and web console
- > I/O control over Modbus/TCP and SNMP protocol
- > Windows/WinCE VB/VC.NET and Linux C APIs
- > Peer-to-Peer I/O without controller

The certification logos shown here apply to some or all of the products in this section. For details, see "Regulatory Approvals" under "Specifications" below.



## Introduction

### Simple Applications without Programming

The ioLogik E2210 can convert a trigger event result directly into a digital alarm output. This can be set up using the ioAdmin UI to define an IF-THEN-ELSE Logic rule, eliminating the need to write programs for PCs or controllers.

### Software Event Counter Input and Pulse Output

Each digital input can be independently configured for DI or Event Counter mode, and output can be independently configured for DO or Pulse Output mode.

## Specifications

### LAN

**Ethernet:** 1 x 10/100 Mbps, RJ45

**Protection:** 1.5 KV magnetic isolation

**Protocols:** Modbus/TCP, TCP/IP, UDP, DHCP, Bootp, SNMP (MIB for I/O and Network), HTTP, CGI, SNTp

### Serial Communication

**Interface:** RS-485-2w: Data+, Data-, GND

**Serial Line Protection:** 15 KV ESD for all signals

### Serial Communication Parameters

**Parity:** None

**Data Bits:** 8

**Stop Bits:** 1

**Flow Control:** None

**Baudrate:** 1200 to 115200 bps

**Protocol:** Modbus/RTU

### Digital Input

**Channels:** 12, source type

**Sensor Type:** NPN, Dry contact

**I/O Mode:** DI or Event Counter (up to 900 Hz)

### Dry Contact:

- Logic 0: short to GND
- Logic 1: open

### Wet Contact:

- Logic 0: 0 to 3 VDC
- Logic 1: 10 to 30 VDC (DI COM to DI)

**Common Type:** 12 points per COM

**Isolation:** 3K VDC or 2K Vrms

**Counter/Frequency:** 900 Hz

**Digital Filtering Time Interval:** Software selectable

**Over-voltage Protection:** 36 VDC

### Digital Output

**Channels:** 8, sink type, 36 VDC, 200 mA

**I/O Mode:** DO or Pulse Output (up to 100 Hz)

**Pulse Wave Width/Frequency:** 10 ms/100 Hz

**Over-voltage Protection:** 45 VDC

**Over-current Limit:** 400 mA (typical)

**Over-temperature Shutdown:** 175°C (min.)

**Output Current Rating:** Max. 200 mA per channel

**Isolation:** 3K VDC or 2K Vrms

### Power Requirements

**Power Input:** 24 VDC nominal, 12 to 48 VDC

**Power Consumption:** 282 mA typical @ 24 VDC

### Physical Characteristics

**Wiring:** I/O cable max. 14AWG

**Dimensions:** 115 x 79 x 45.63 mm (4.53 x 3.11 x 1.8 in)

**Weight:** 215 g

### Environmental Limits

**Operating Temperature:** -10 to 60°C (14 to 140°F)

**Storage Temperature:** -40 to 85°C (-40 to 185°F)

**Ambient Relative Humidity:** 5 to 95% (non-condensing)

### Regulatory Approvals

**EMI:** FCC Part 15, CISPR (EN55022) class A  
**EMS:** IEC 61000-4, IEC 61000-6  
**Shock:** IEC 60068-2-27  
**Freefall:** IEC 60068-2-32  
**Vibration:** IEC 60068-2-6

### Warranty

**Warranty Period:** 2 years  
**Details:** See [www.moxa.com/warranty](http://www.moxa.com/warranty)

### Dimensions (unit = mm)

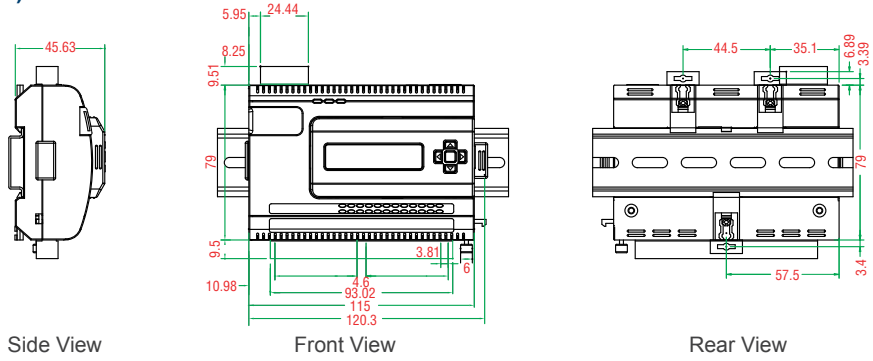

### Pin Assignment

#### I/O (left to right)

1	2	3	4	5	6	7	8	9	10	11	12	13	14	15	16	17	18	19	20	21	22	23	24
DI.COM	DI0	DI1	DI2	DI3	DI4	DI5	DI6	DI7	DI8	DI9	DI10	DI11	DI.GND	DO.PWR	DO0	DO1	DO2	DO3	DO4	DO5	DO6	DO7	DO.GND

### Ordering Information

**ioLogik E2210:** Active Ethernet I/O with 12 digital inputs and 8 digital outputs  
**LDP1602:** LCD module with 16 x 2 text display and 5 buttons